	<p>Features</p> <ul style="list-style-type: none"> - 1024x768 resolution - Resistive touch screen - All metal construction - Toolless quick removal of hard drive - All solid state design (fanless) - Dual Ethernet ports - 2 RS232 ports - 1 RS485 port - 4 USB ports - HDMI for secondary display up to 1920x1080 - Fully loaded and configured to be ready to use - Includes latest version of AdvancedHMI software
---	--

Description

The AdvancedHMI line of panel PCs are specifically designed to provide maximum openness, reliability, and capabilities. The hardware has been designed with serviceability in mind with features such as a toolless quick release solid state hard drive. Pre-loaded with a Windows operating system that is configured for optimum performance as an HMI in an industrial environment. When used with the AdvancedHMI software, a flexible and cost effective machine interface can be achieved. Can also be used as a general purpose PC.

Specifications

Motherboard	Processor	Intel Celeron J1900 Quad Core
	Clock	2.0 Ghz
	Memory	4Gb
	Storage	256Gb SATA SSD
	Network	2 x Realtek 10/100/1000 Mbps
	Internal Expansion	1 x Mini-PCIe 1 x mSATA
	I/O Ports	2 x RS232, 1 x RS485 1 x USB 3.0, 3 x USB 2.0
Operating System	Default Image	Windows 10 Pro
Physical	Overall Dimensions	406mm x 312mm x 58mm
	Cutout Dimensions	391mm x 297mm
Power	Input	9-36VDC
		32W
LCD Screen	Resolution	1024x768
	Intensity	500 cd/m2
	Contrast Ratio	700:1
Touch Screen	Life Expectancy	35 million
Environment	Operating Temperature	0 °C to 50 °C
	Protection	IP65 Front Bezel

Dimensions

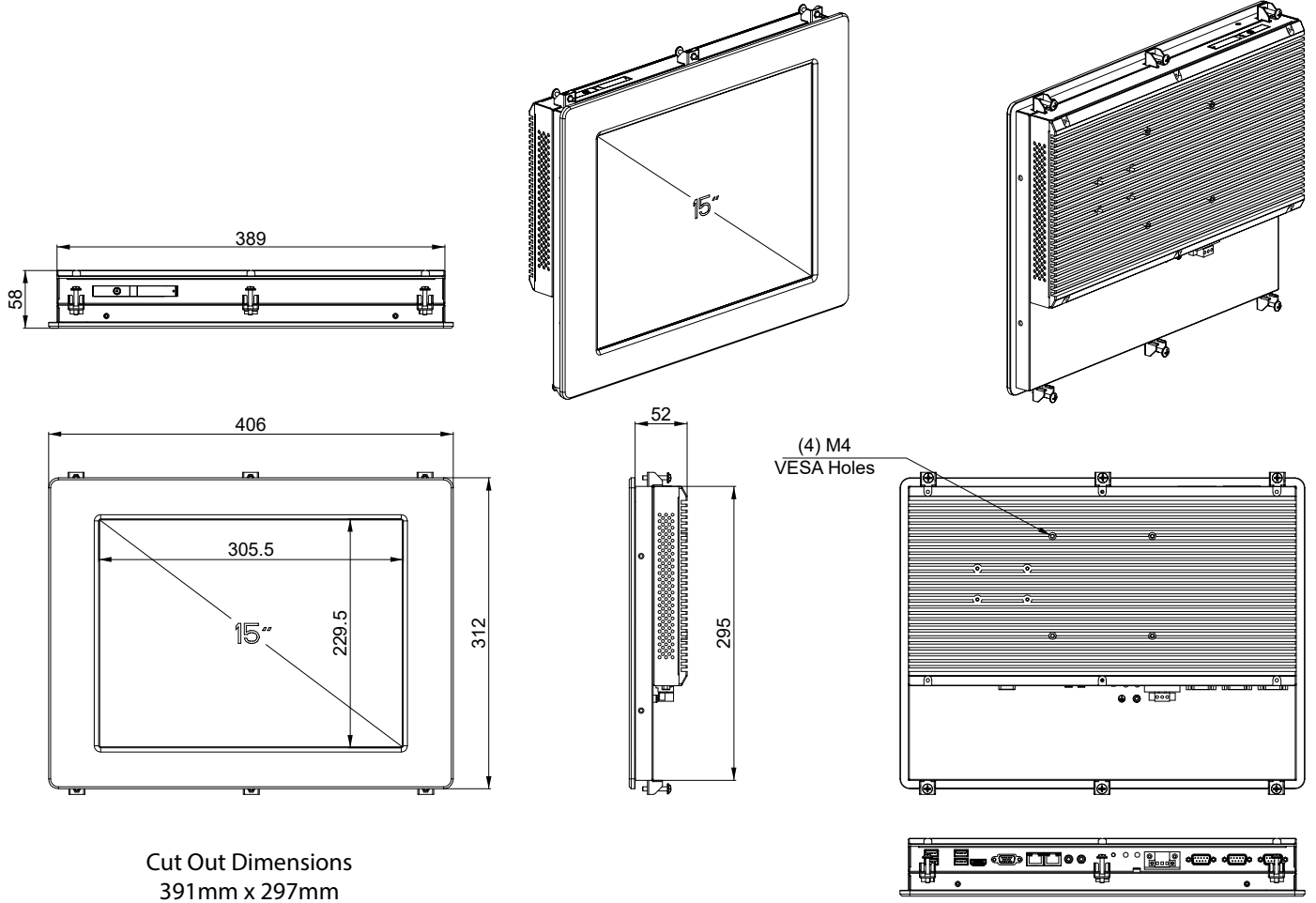

Connections

